





# Wisconsin Uniform Plumbing Code

Proposed Effective Date: January 1, 2009

Based on Plan Received Date

OR

Based on Installation Date

# PLEASE HELP SPREAD THE WORD!

WHEN: Dec 10 & 17, 2008

7:00 a.m. to 8:30 a.m.

WHERE: Your office!

WHO: Your contractors, you  
and Lynita

HOW: Internet connection

WHY: Increase compliance,  
decrease violations, decrease  
headaches



# PLEASE HELP SPREAD THE WORD!

- Invite the plumbers
- Buy some donuts
- Set up the room
- Listen, watch, participate
- Discuss
- Hand out and collect con ed forms
- Enter student info!



# Chapter 62.2900

- Composting or incinerating, OK
- Privies OK for . . .
  - 3-season facilities
  - Religious schools & assemblies
  - As approved by Dept.
- Portable toilets OK for . . . .
  - 12 days
  - As approved by Dept.



# Chapter 62.2900

- Lavatories not required where privies & portable toilets are used
- Hand sanitizer required for composting & incinerating toilets
- No service sinks required for privy, only sites



# Comm 81.01 (5)

## Air-break

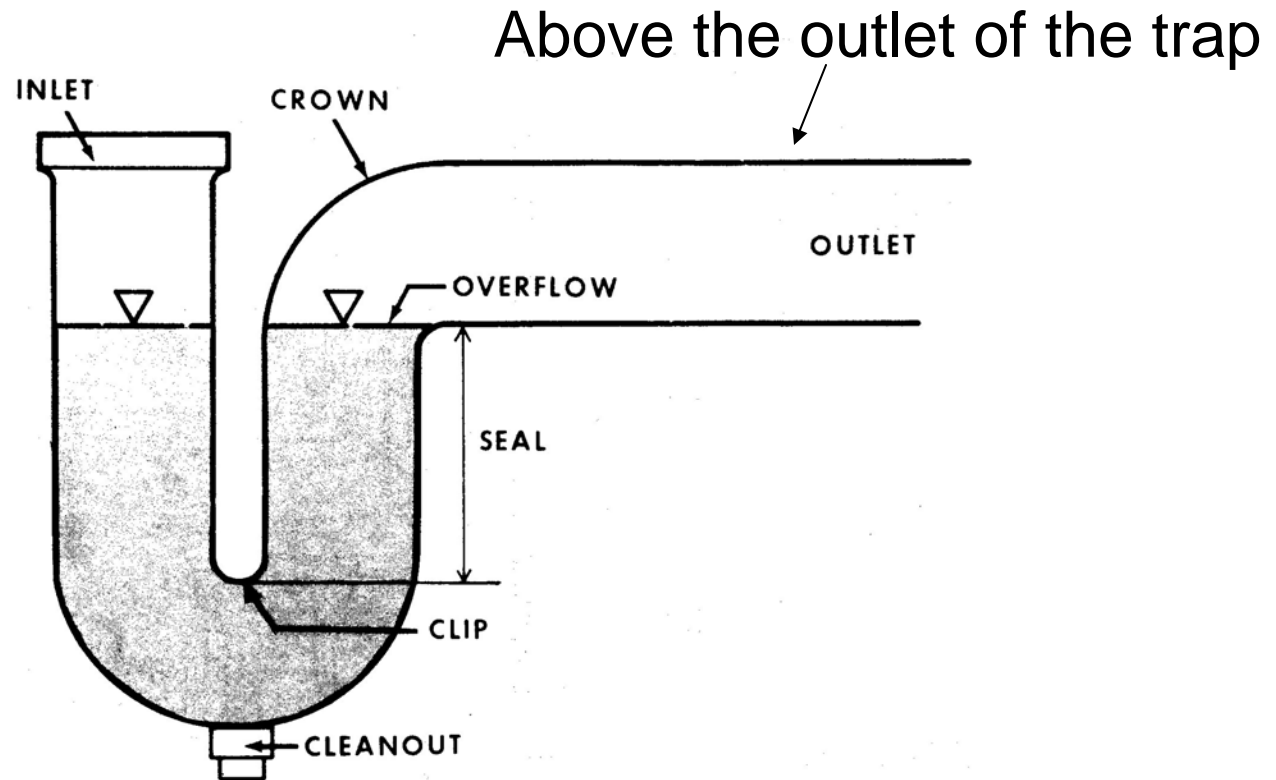

# Deleted “old” CCC Names

- 81.01 (20) Back siphonage backflow vacuum breaker
- 81.01 (199e) Pressure vacuum breaker
- 81.01 (209e) & (209m) RP & RP detector
- 81.01 (252e) SVB

# 81.01 (120) High hazard

“Toxic” substance or solution



# 81.01 (147) Low hazard



“Non toxic” substance or solution

a) Listed by NSF for nonfood compounds

b) Acceptable to FDA for food additives

c) Acceptable for contact with potable water or deemed non-toxic by third party acceptable to the department.

d) Deemed non-toxic by the department

81.01 (152) Manufactured  
home/community



# 81.01 (156) MPP Systems

Multipurpose piping system, means a type of water distribution system conveying potable water to plumbing fixtures and appliances and automatic fire sprinklers with the intention of serving both domestic and fire protection needs.

82.20-1

- **Hospital disinfection**

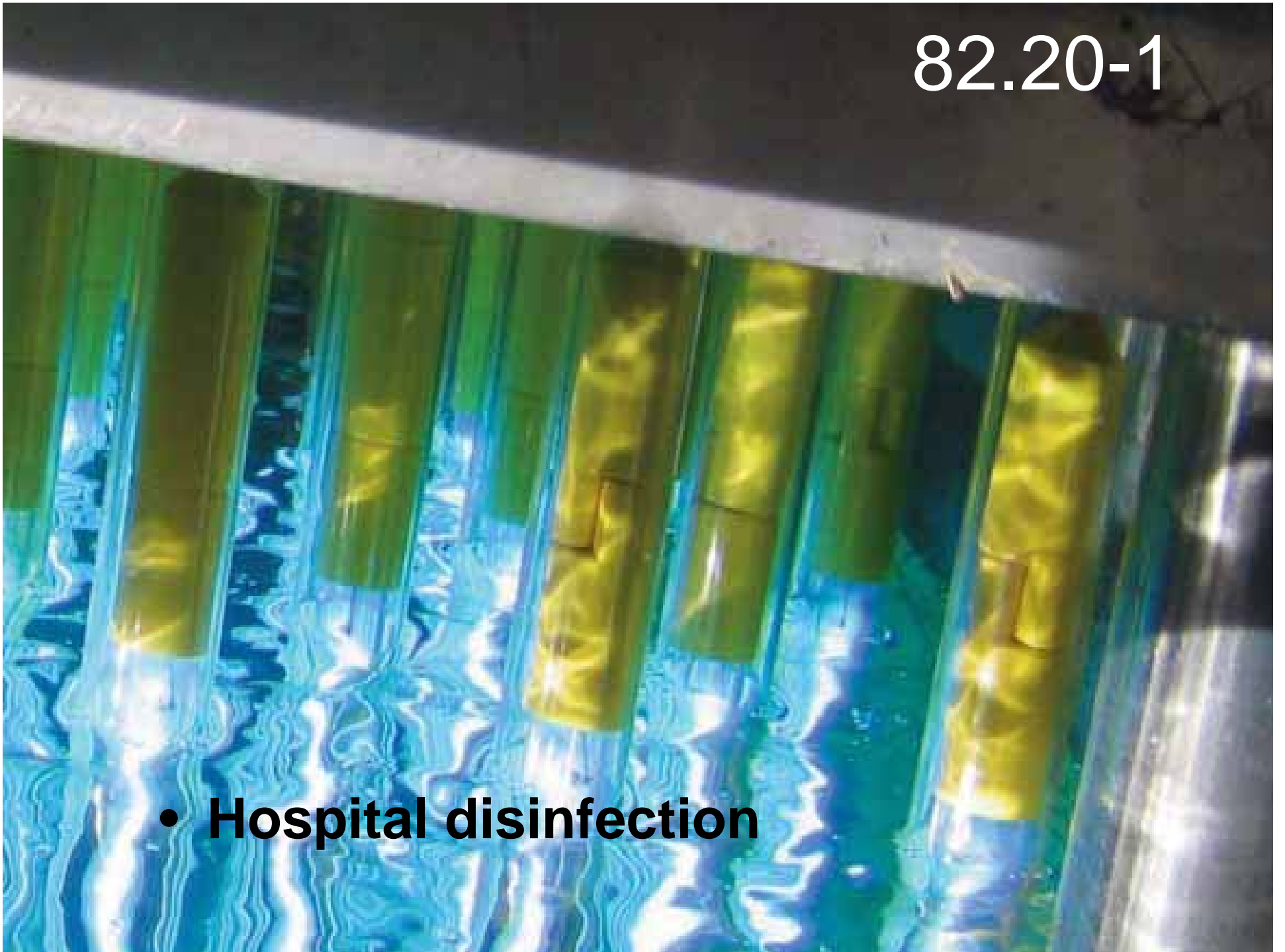

# New Section! 82.22

## Maintenance and Repairs

- Existing systems may remain:
  - 1. Plumbing installed in accordance with code at the time of installation
  - 2. Plumbing currently conforms to code
- **EXCEPT**
  - When a hazard to life, health or property exists or is created by an existing system, that system shall be repaired or replaced.

# What's OK to stay?

- Single check on fire protection?
- Yard hydrants?
- Chemical pot feeder on boiler?
- Dual check w/vent on dental units?

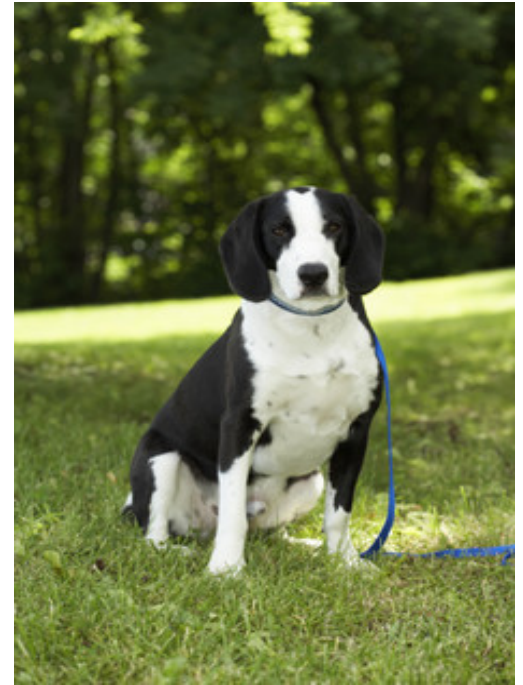

# Table 82.22-1 Testing & Submitting Requirements

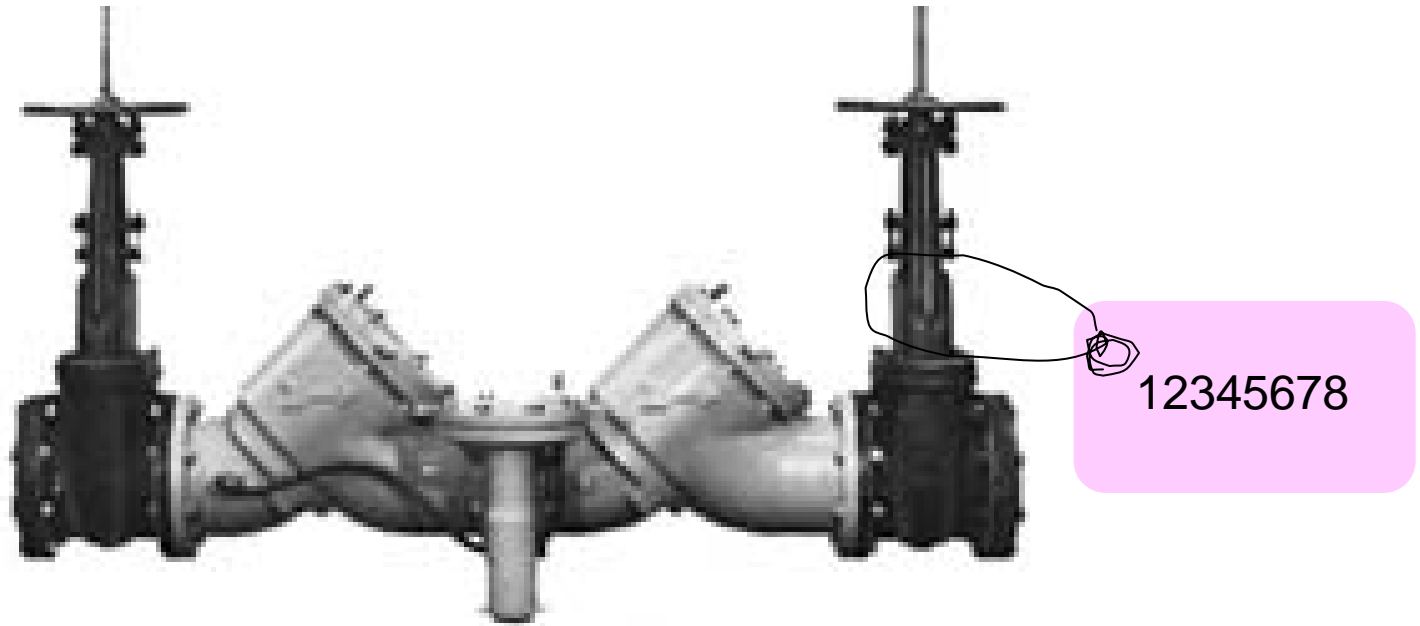

# 82.33 (7) Air Gap Installation

- Air gap
  - 1" or less in diameter,  $\geq 2 \times$  ID air gap
  - $>1$ " in diameter, 2" air gap
  - ASSE 1021 Manufactured Dishwasher air gap
  - ASME A112.1.3 Manufactured drain air gap fitting

# 82.33 (7) Air Gap Installation



ASSE 1021  
Dishwasher air gap



ASME A112.1.3  
Manufactured air gap

# 82.33 (7) Air Gap Marking



ASSE 1021

Marking visible after install

Mfg name or Trademark

Type or Model #

Critical Level



ASME A112.1.3

Mfg name or Trademark

Type or Model #

Critical Level

Flow direction indicator

# 82.33 (9) Clothes Washer Standpipes

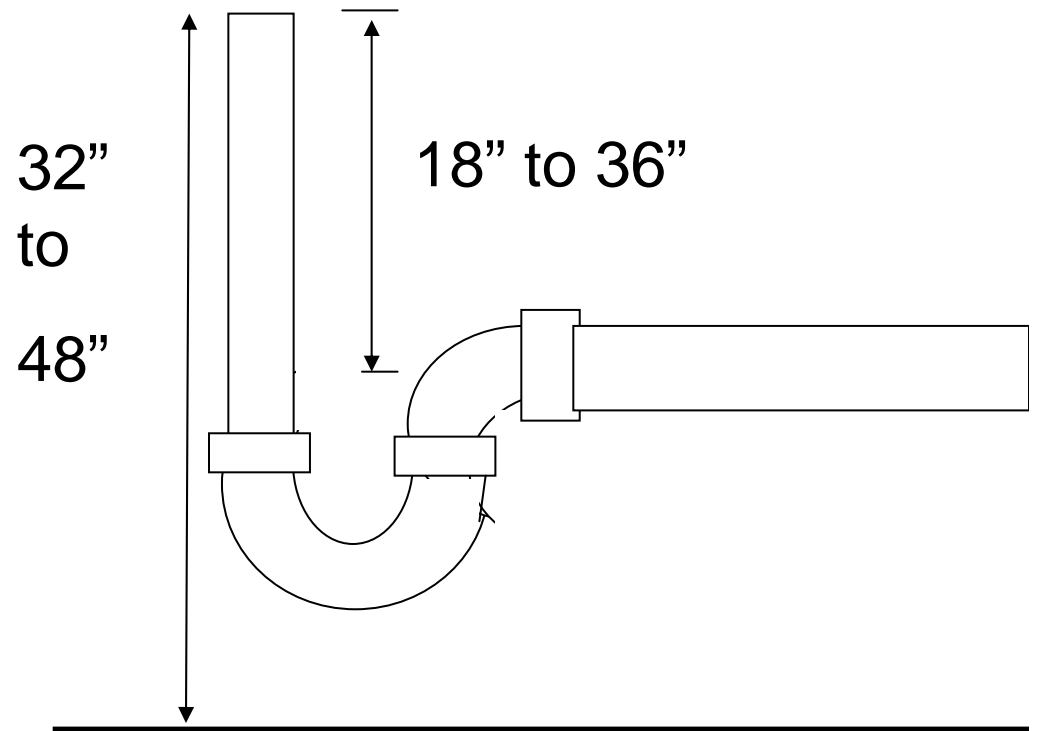

# 82.34 (3) Blackwater Reuse

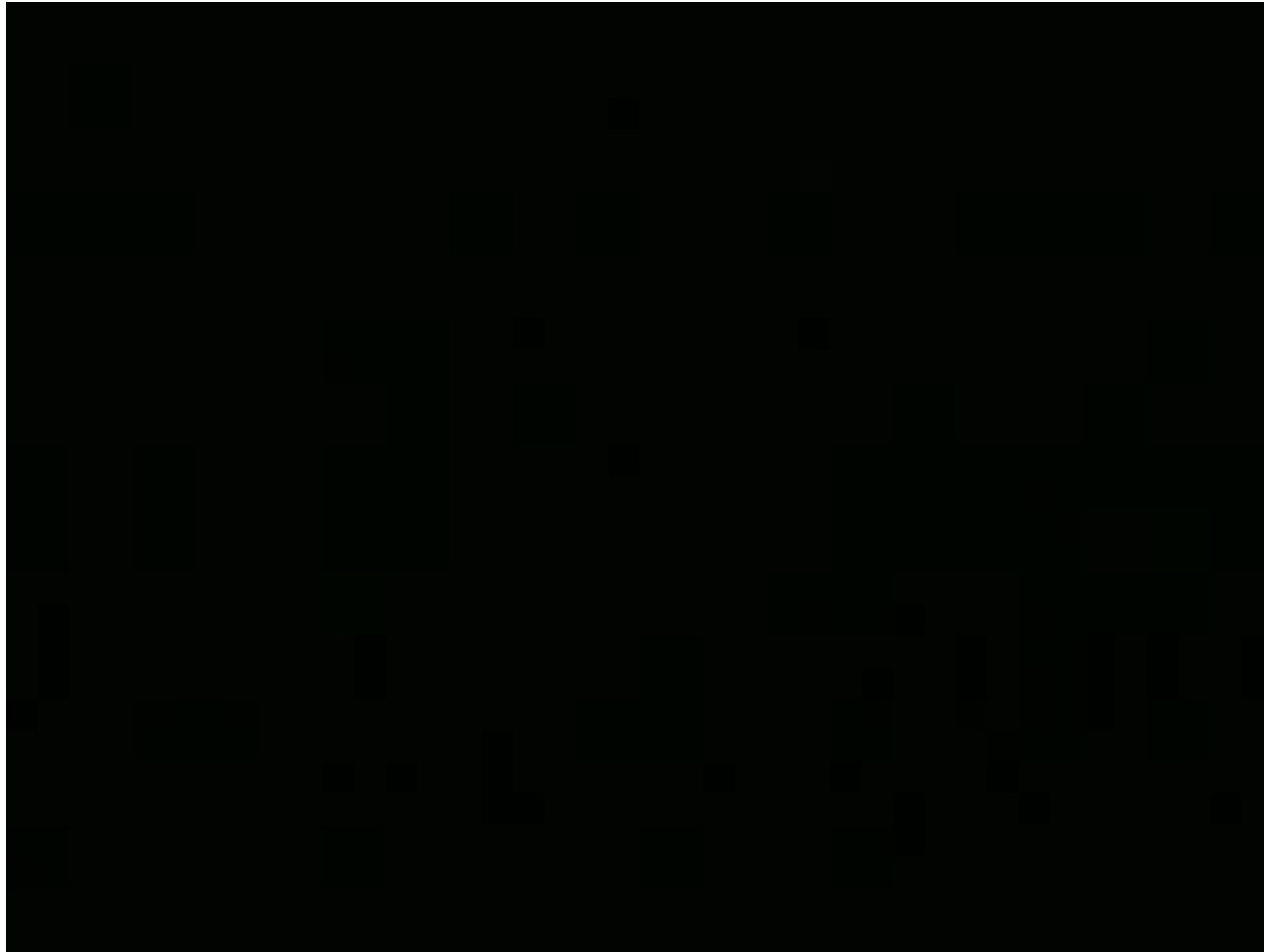



# 82.37 Campsite water supply



$\geq 18$  inches to finished grade



# Table 82.38-1 Revisions

- Residential living unit air conditioner condensate
- Secondary roof drain requirements
- Fire sprinkler test discharge

# 82.40 (3) MPP Systems

- Updated MPP language for 2007 13D standard
- Warning tags required:
- “The number and location of sprinklers in this system conform with NFPA 13D”
- “The number and location of sprinklers in this system does not conform with NFPA 13D”



# Table 82.40-3e.

- Just the water treatment device.
- Not the whole system
- Individual dwellings

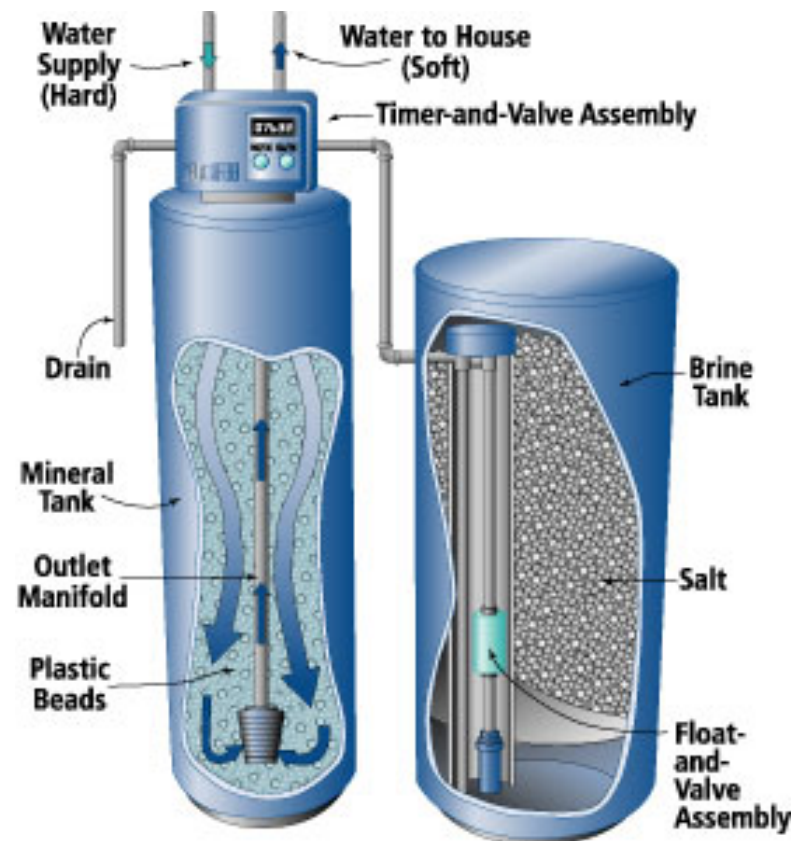

# 82.40-3e Water Treatment

Home demand in wsfu	Total
2 t&s flush tank bathroom groups	8.0
1 kitchen sink	1.5
1 dishwasher	1.0
1 automatic clothes washer	1.5
1 laundry tray	1.5
2 hose bibbs	<u>6.0</u>
	19.5

# 82.40-3e Water Treatment

Home demand in wsfu	Total
2 t&s flush tank bathroom groups	8.0
1 kitchen sink	1.5
1 dishwasher	1.0
1 automatic clothes washer	1.5
1 laundry tray	1.5
2 hose bibbs	<u>N/A</u>
	13.5

# 82.40-3e Water Treatment

13.5 wsfu = 7 gpm

Use 7 gpm for friction  
loss through softener



# 82.40 (8) Ion exchange



**Demand Regeneration Required  
(Except for iron reduction)**

# 82.70 Treatment Standards

- Clothes washing –  
Taken out of #2, Added to #10



# 84.20 (3) Conservation



- Lavatories – 2.2 gpm @ 60 psig
- Metering Lavs - .25 gal. per cycle @ 80 psig
- Shower heads – 2.5 gpm @ 80 psig
- Sink faucets – 2.5 gpm @ 80 psig
- Urinals – 1 gal per flush @ 80 psig
- Water Closets – 1.6 gal/flush



# Direct Forfeiture Rule Draft



# Direct Forfeiture Rule Draft



- No appropriate license without an MP in charge
  - 1<sup>st</sup> – \$1,000
  - 2<sup>nd</sup> - \$1,500
  - 3<sup>rd</sup>- \$2,000

# Direct Forfeiture Rule Draft



- No appropriate license with an MP in charge
  - 1<sup>st</sup>- \$100
  - 2<sup>nd</sup>- \$500
  - 3<sup>rd</sup>- \$1,000

# Direct Forfeiture Rule Draft



- Allowing the use of the MP license for obtaining a permit
  - 1<sup>st</sup>- \$1,000
  - 2<sup>nd</sup>- \$1,500
  - 3<sup>rd</sup>- \$2,000

# Direct Forfeiture Rule Draft



- MP who allows someone to work under their license without that MP being responsible.
  - 1<sup>st</sup>- \$500
  - 2<sup>nd</sup>- \$1,000
  - 3<sup>rd</sup>- \$2,000

# Direct Forfeiture Rule Draft



- An MP using unlicensed or inappropriate-licensed staff
  - 1<sup>st</sup>- \$1,500
  - 2<sup>nd</sup>- \$1,750
  - 3<sup>rd</sup>- \$2,000

# Direct Forfeiture Rule Draft



- A person who engages in the business of “superintending” plumbing
  - 1<sup>st</sup>- \$1,000
  - 2<sup>nd</sup>- \$1,500
  - 3<sup>rd</sup>- \$2,000

# Direct Forfeiture Rule Draft



- Cross Connection Control Device Tester without a registration
- 1<sup>st</sup> - \$500
- 2<sup>nd</sup> - \$1,000
- 3<sup>rd</sup> - \$2,000

# Direct Forfeiture Draft

- Appeals to the Division Administrator
- Appeal must be filed within 30 days
- Hearing may be granted
- Further appeal to the Secretary
- Further appeal through the court system



# Stop work/stop use

- Comm 3.13,  
Effective 8/1/06
- “Issue an order to  
immediately  
cease. . . .”
  - Construction
  - Use of building,  
component,  
structure or  
mechanical device



# Questions?



Remem



**This code isn't effective  
until January 2009**

THANK  
YOU